



شرکت مهندسی

جلاپردازان الوند

**Jala
Pardazan
Alvand**

Technical Engineering Company



 WWW.JPA.CO.IR

 INFO@JPA.CO.IR

Forging, Casting & Machining

شرکت مهندسی جلاپردازان الوند با حدود سه دهه سابقه در تولید انواع قطعات صنعتی، جزء شرکت های موفق در صنعت ریلی ایران می باشد، این شرکت با استقرار سیستمهای مدیریت کیفیت، آزمایشگاه کنترل کیفیت، بهروری در تولید، محصولات استاندارد با قیمت مناسب تولید می نماید. محصولات این شرکت با روشهای فورج گرم، ریخته گری و ماشین کاری تولید می گردد.

زمینه های فعالیت شرکت در حوزه های صنایع ریلی، صنایع خودرو سازی، صنایع نفت و گاز و ابزارآلات مکانیکی می باشد.

Engineering company Jala Pardazan Alvand with nearly 3 decades of experience in creating various industrial products, is one of the best companies in the Railway industrial of Iran. With Establishing quality management systems, controlling labs, efficiency in production, this company creates standard products with suitable cost. Products gets created with unveiling warm forge, casting and machining.

The fields of activity of the company are in the fields of railway industries, automotive industries, oil and gas industries, and mechanical tools.

انواع گوشواره فنر

Link (140-172-292-325)

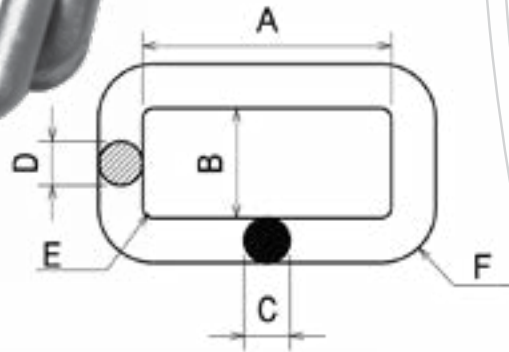

Part No.	Dimention(mm)						Material	Weight (kg)	Application
	A	B	C	D	E	F			
JP004FP005	325	62	25	25	R6	R31	CK45 DIN 1.1191	3.3	BOGIE
JP005FP066	292	62	25	25	R6	R31		3	
JP006FP034	172	62	26.5	25	R6	R31		2.5	
JP007FP033	140	62	25	25	R6	R31		1.9	

مانع گوشواره (لقمه)

Bearing Stone

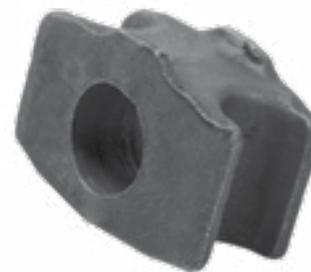
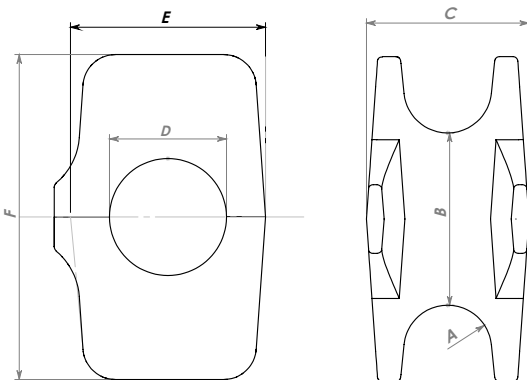

Part No.	Dimention(mm)						Material	Weight (kg)	Application
	A	B	C	D	E	F			
JP001FP006	R 13.5	52	50	36	60	100	Ck 35	1.1	BOGIE

شمشیرک واگن دو محوره

Shaft for Brake Shoe (LSD1)

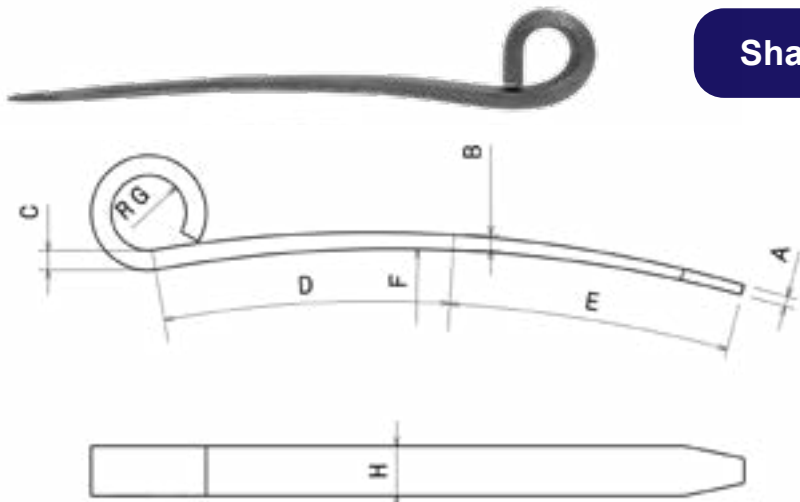

Top view
Scale: 1:2

Part No.	Dimension(mm)								Material	Weight (kg)	Application
	A	B	C	D	E	F	G	H			
JP009FP015	4	6	8	120	120	R540	15	20	55 CR3 DIN:1.7176	0.35	Wagon Brake System

شمشیرک روسی و آلمانی

Shaft for Brake Shoe

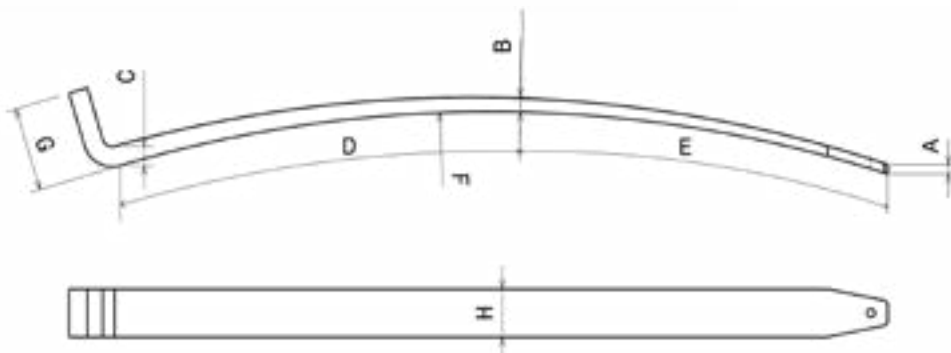

Part No.	Dimension(mm)								Material	Weight (kg)	Application
	A	B	C	D	E	F	G	H			
JP009FP015	4	6	8	160	160	R540	8	20	55 CR3 DIN:1.7176	0.33	Wagon Brake System
JP052FP000	4	6	8	190	190	R540	8	20		0.43	

جعبه یاتاقان

Axle Bearing Box

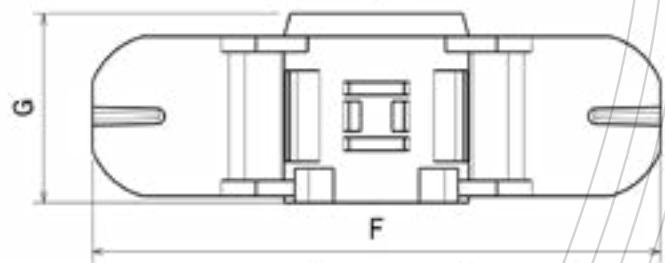
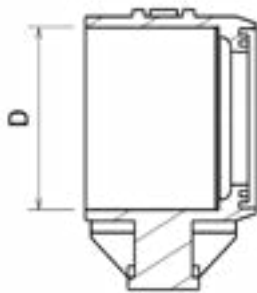
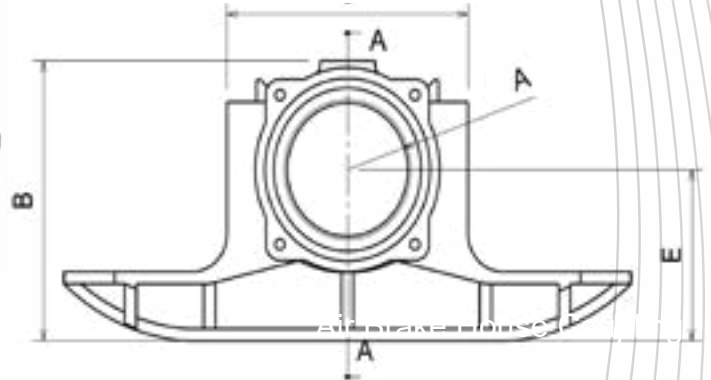
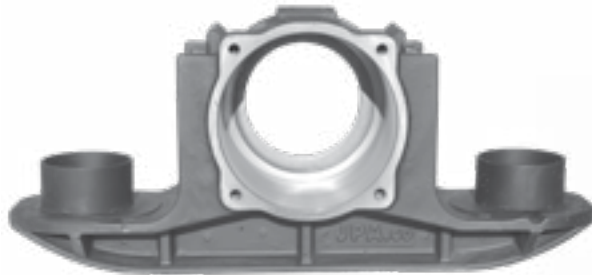
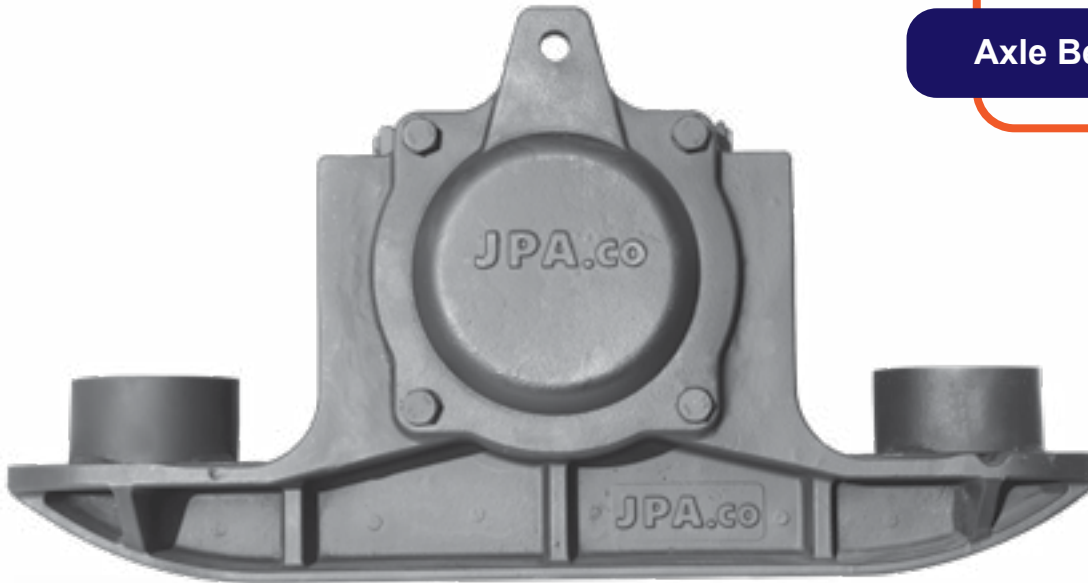

Section view A-A
Scale: 1:8

Part No.	Dimention(mm)							Material	Weight (kg)	Application
	A	B	C	D	E	F	G			
JP018FP010	175	368	350	240	225	825	248.5	GS-45 DIN:1681	70	BOGIE

راهنمای جعبه یاتاقان

Bearing Box Guide

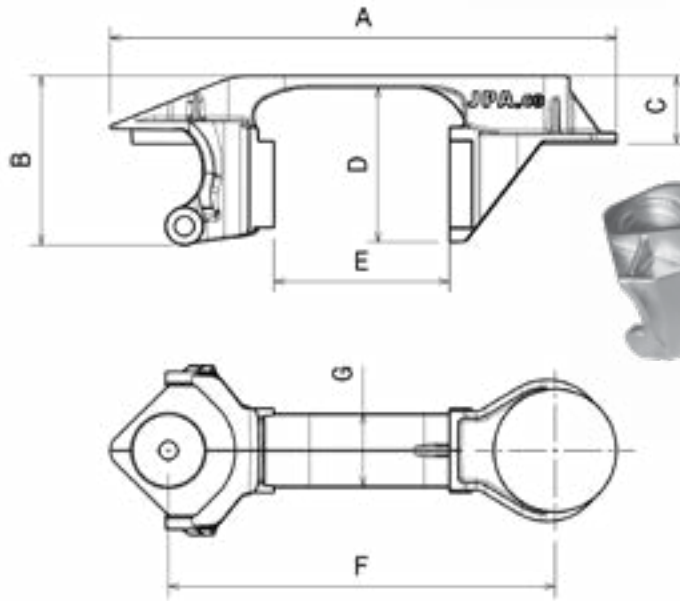

Part No.	Dimention(mm)							Material	Weight (kg)	Application
	A	B	C	D	E	F	G			
JP018FP011	825	276	111	252	286	630	120	GS45	42	BOGIE

قاب کفشک ترمز

Brake Block Holder

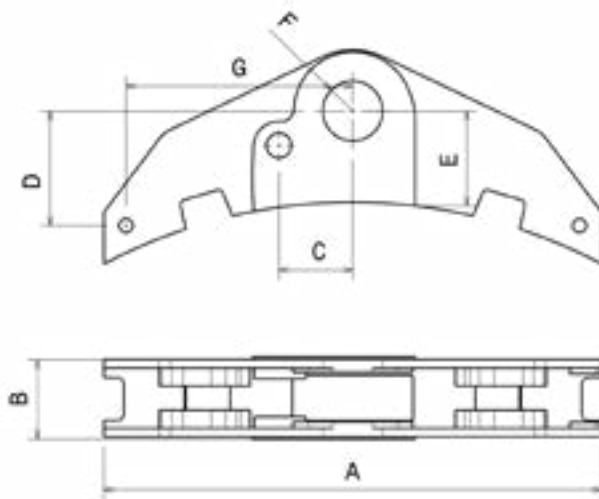

Part No.	Dimention(mm)							Material	Weight (kg)	Application
	A	B	C	D	E	F	G			
JP0053FP068	500	80	75	115	90	70	232	GS-45 DIN:1681	10.7	BOGIE

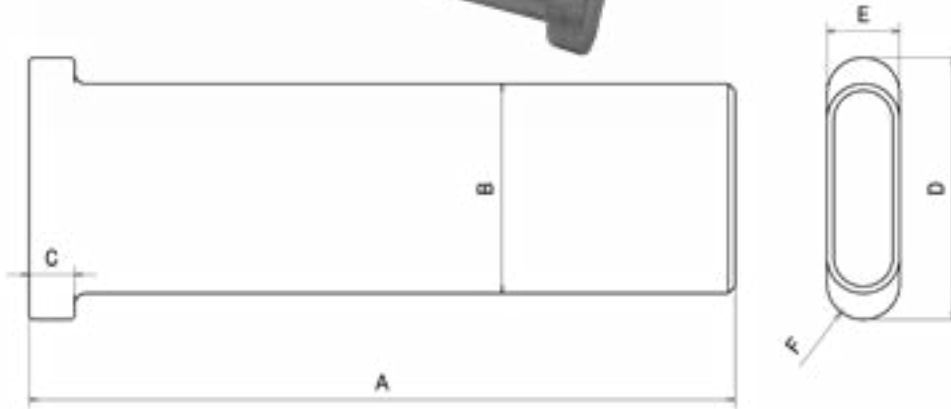

Part No.	Dimention(mm)							Material	Weight (kg)	Application
	A	B	C	D	E	F	G			
JP014FP704	310	92	20	115	32	R16		Mo40 DIN 1.7225	6.8	AUTOMATIC COUPLER

والیک کتابی

Coupler Yoke Pin

آویز پاندولی

Suspension Pin

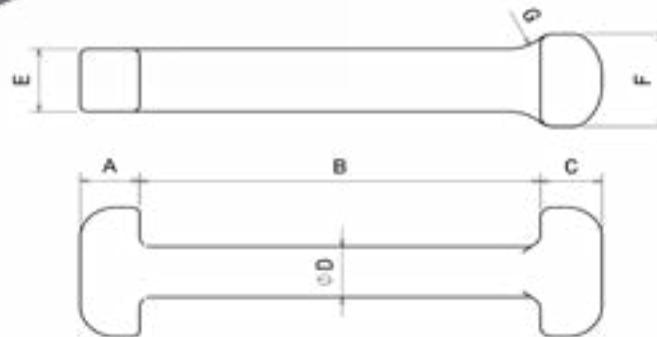
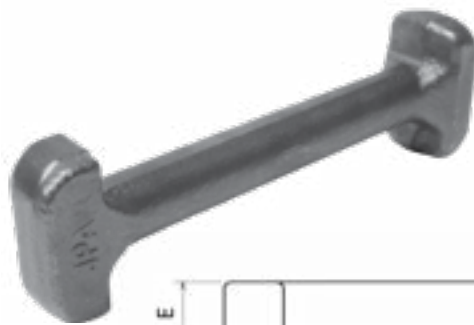

Part No.	Dimention(mm)							Material	Weight (kg)	Application
	A	B	C	D	E	F	G			
JP012FP705	25	170	26	25	25	40	R20	MO40 DIN:1.7225	1.4	Automatic coupler



انواع والیک

Pin



انواع خاموت

Bracket

شتر گلویی

Connection Rod

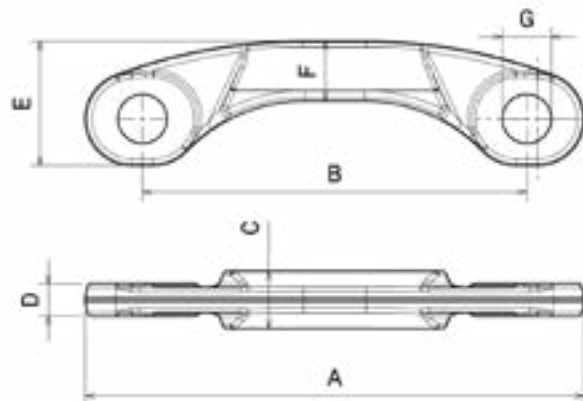

Part No.	Dimention(mm)							Material	Weight (kg)	Application
	A	B	C	D	E	F	G			
JP018FP069	610	470	70	40	152	73	Ø60	RST42-2	RST42-42 DIN:17100	BOGIE



بکس دینامیکی

Shock Absorber
Spring Position

انواع آویز

Brake Block Hanger

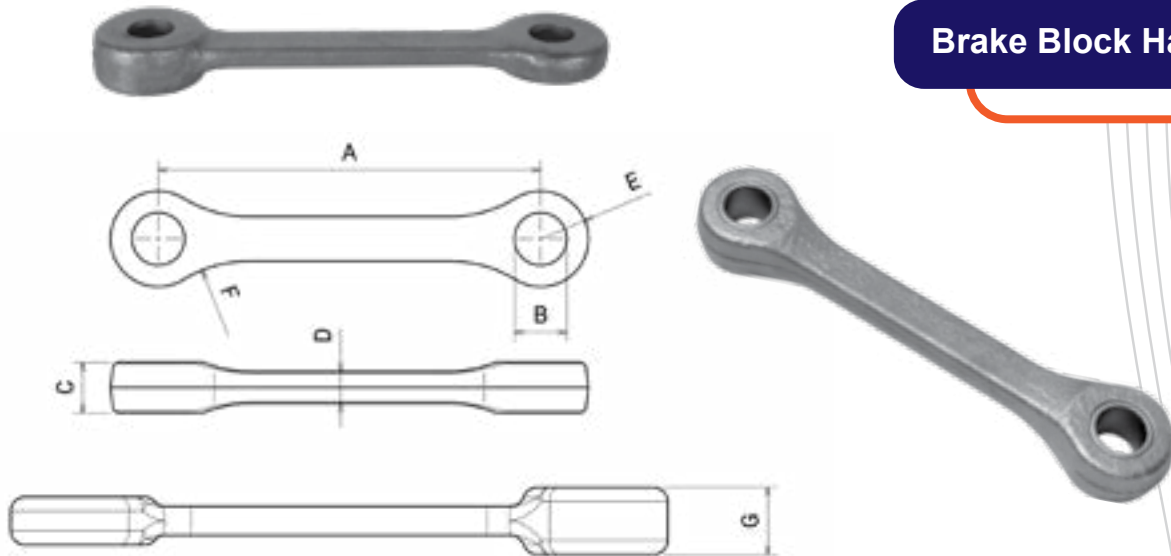

Part No.	Dimention(mm)							Material	Weight (kg)	Application
	A	B	C	D	E	F	G			
JP033FP081	240	33	33	20	R28.5	R80		RST42-42	1.8	BOGIE
JP034FP053	225	33	33	20	R28.5	R80			1.65	
JP035FP091	215	33	20	12	R30	40	28	CK35	1.24	

لینک ۱۵۰ و ۱۸۰

Break Lever 150-180

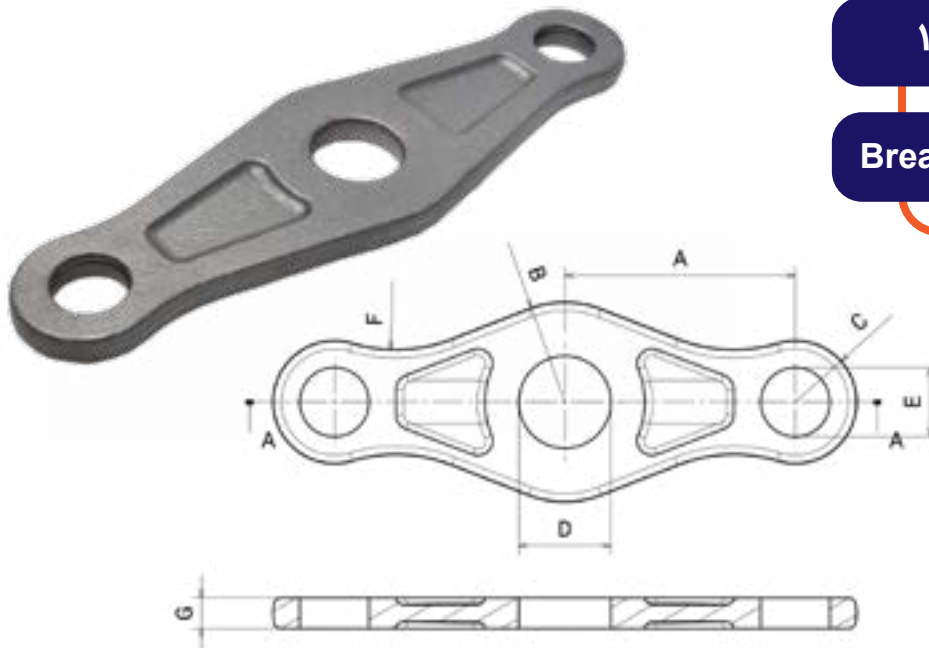

Part No.	Dimention(mm)							Material	Weight (kg)	Application
	A	B	C	D	E	F	G			
JP056FP001	180	R65	R40	∅60	∅45	R100	20	ST52-3	4.3	BOGIE
JP046FP001	150	R65	R40	∅60	∅45	R100	20		3.8	



Part No.	Dimention(mm)							Material	Weight (kg)	Application
	A	B	C	D	E	F	G			
JP046FP766	426	80	122	M20x2.5	27.6	6.2		CK45 DIN: 1.1191	4.1	AUTOMATIC COUPLER

میله لاترن

Coupler Yoke Pin

لوله هوا

Air Brake Hose Coupling



پابند کج

Axle Guide

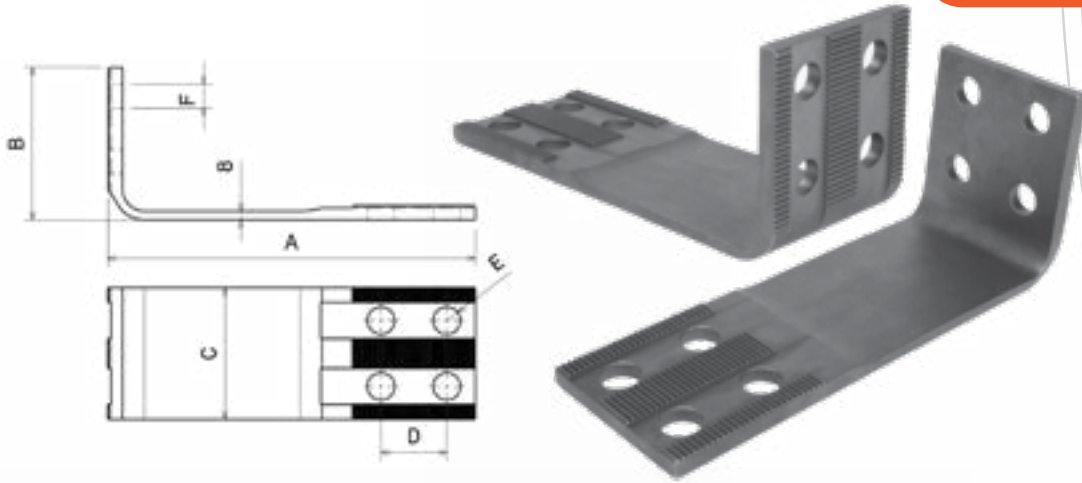

Part No.	Dimention(mm)							Material	Weight (kg)	Application
	A	B	C	D	E	F	G			
JP029FP000-00	335.5	139	120	60	25	22	8	50Crv4	4	BOGIE

پابند راست

Axle Guide



Part No.	Dimention(mm)							Material	Weight (kg)	Application
	A	B	C	D	E	F	G			
JP030FP000-00	616	120	7	17	60	60	∅41	50Crv4	5.7	BOGIE

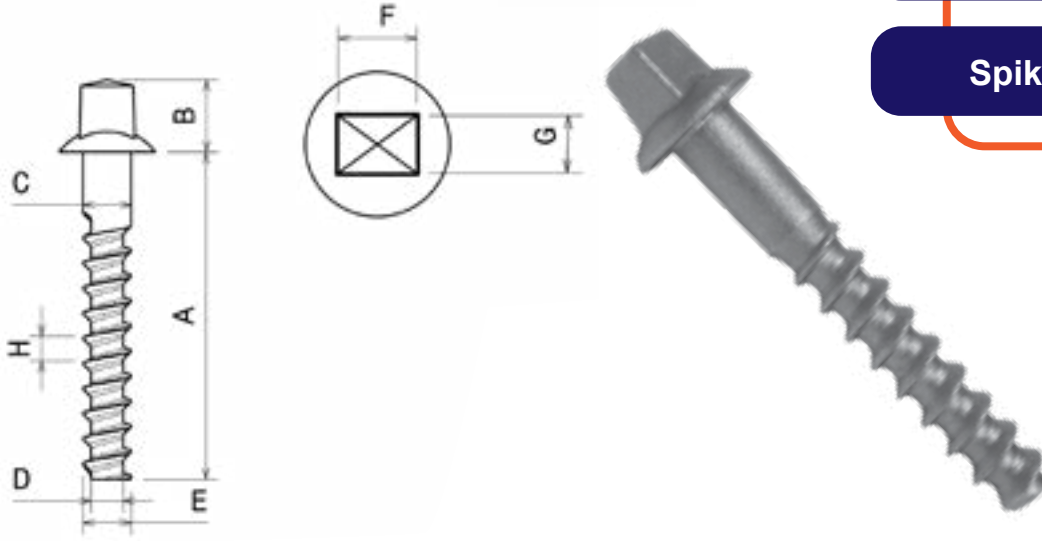

پیچ تراورس

Spike Screw

Part No.	Dimension(mm)								Material	Weight (kg)	Application
	A	B	C	D	E	F	G	H			
JP001FP015	163	36	24	16	24	26	19	12.5	ST37	0.62	Component Rail

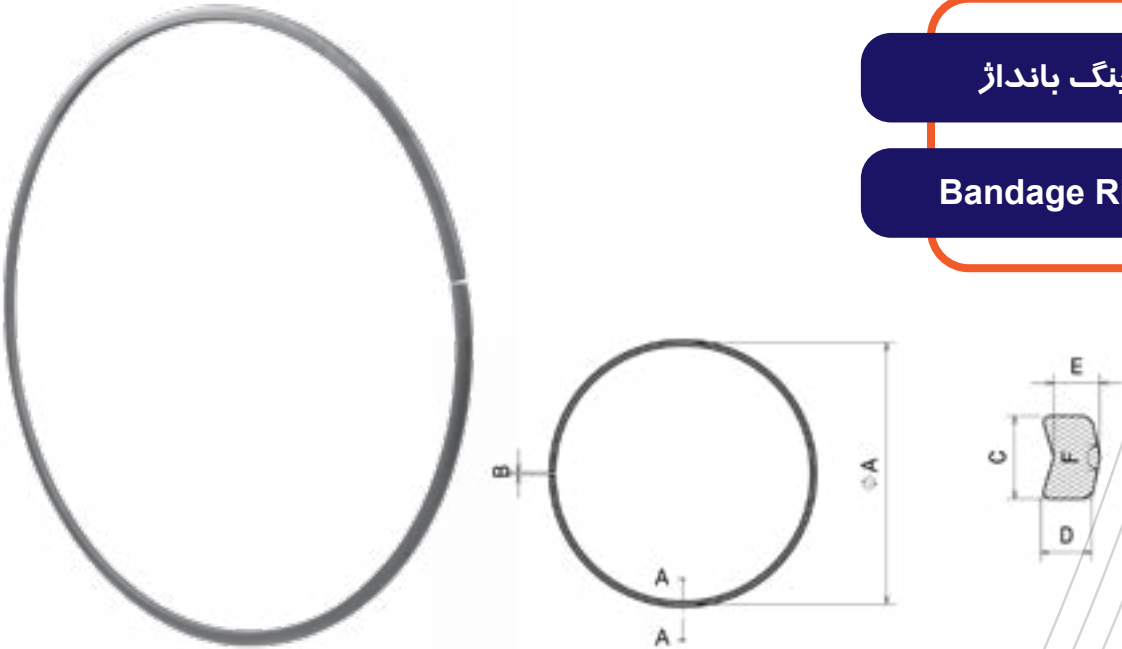

رینگ بانداژ

Bandage Ring

Part No.	Dimension(mm)								Material	Weight (kg)	Application
	A	B	C	D	E	F	G				
JP022FP806	850	2	18	11	10	158		ST37	4	Wheel of Wagon	
JP024FP000	770	2	18	11	10	158		DIN:1.0037	3.2		

كفش خط U33

Track Brake Shoe

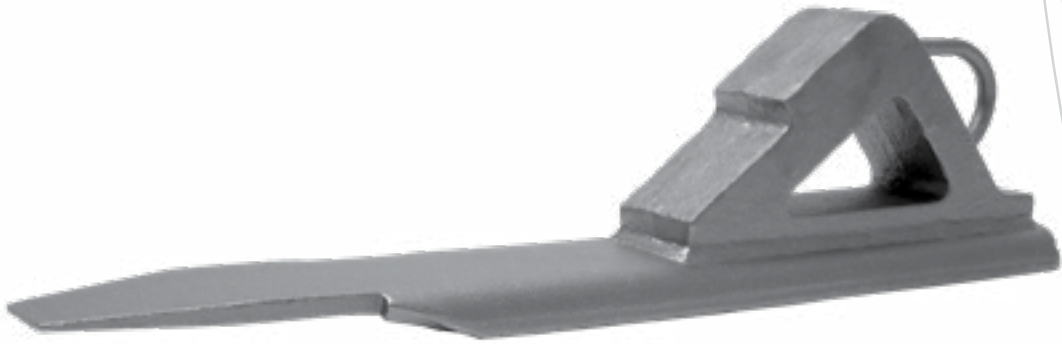

قفل سوزن

Switch Lock

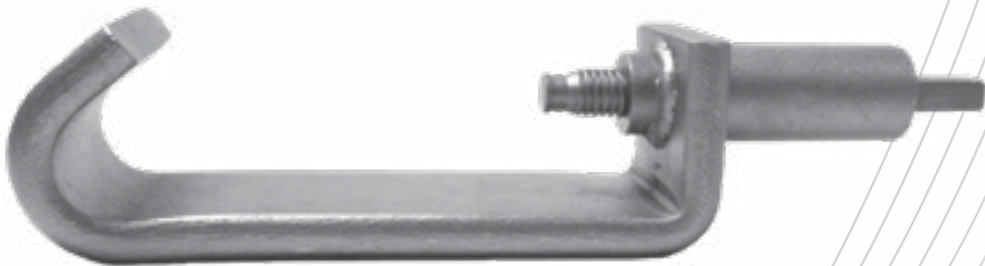
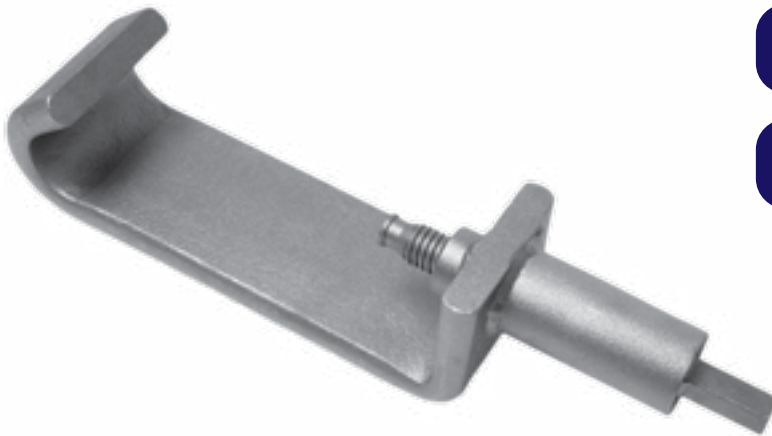

ضربه گیر قدر و تامپون

Tampon & Feder Buffers



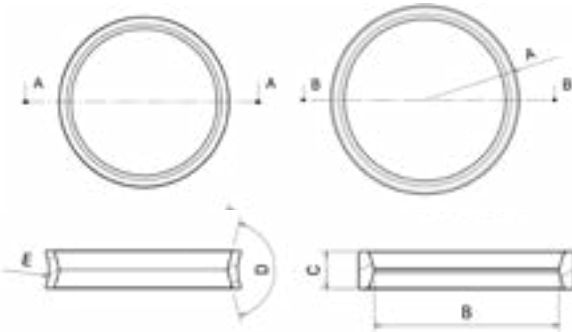

Part No.	Dimension(mm)					Material	Weight (kg)	Application
	A	B	C	D	E			
JP017FP095	243	209	42.5	146.7		58CRMOV4	2.68	
JP017FP142	165.7	142	32	150	40	60SiCr 7	0.68	

رینگ خارجی

Buffer Ring

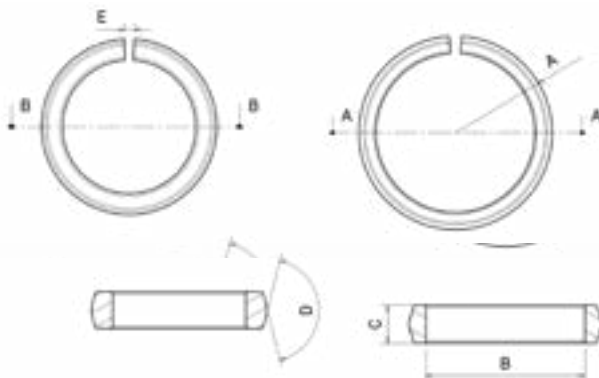

Part No.	Dimension(mm)					Material	Weight (kg)	Application
	A	B	C	D	E			
JP017FP097	225.4	185	44	146.7	14.5	58CRMOV4	2.38	
JP017FP143	153.4	116.5	32	151.9	9	60SiCr 7	1.74	

رینگ چاکدار

Buffer Ring

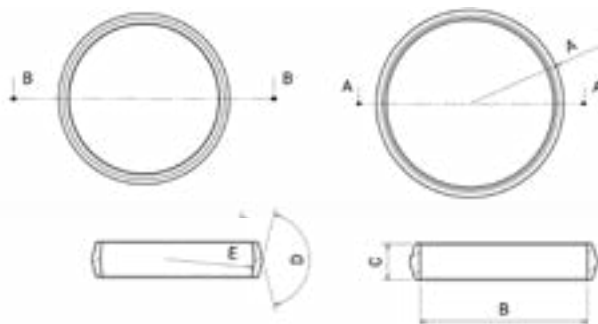

Part No.	Dimension(mm)					Material	Weight (kg)	Application
	A	B	C	D	E			
JP017FP096	223	199.4	43.7	146.7		58CRMOV4	1.98	
JP017FP141	152.4	137	32	151	80	60SiCr 7	0.68	

رینگ داخلی

Buffer Ring



قلاب زنجیری

Screw Coupling



گوشواره Y25

Link Y25 (LSD1)

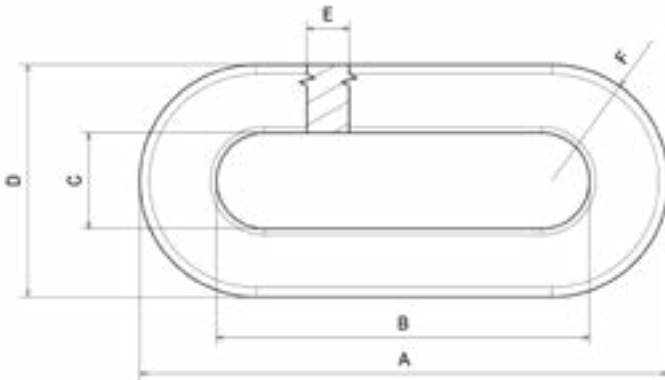

Part No.	Dimention(mm)							Material	Weight (kg)	Application
	A	B	C	D	E	F	G			
JP008FP003	137	97	25	60	12	R30		CK45	0.5	BOGIE
JP051FP000	143	103	31	66	16	R33		DIN: 1.1191	0.7	

قطعات خودرویی

Automotive Parts





WWW.JPA.CO.IR

INFO@JPA.CO.IR



Unit8 ,3th floor, No 45, Karimkhan Ave,
South Kheradmand, Tehran, Iran



+98 2188103437



+98 2188103436

خیابان کریم خان زند، خیابان خردمند جنوبی، پلاک ۴۵،

طبقه ۳، واحد ۸

کدپستی: ۱۵۸۴۸۵۳۱۱۸

۸۸۱۰۳۴۳۷ - ۸۸۳۴۸۳۰۵ - ۸۸۳۴۸۳۰۶



۸۸۱۰۳۴۳۶

